

Model: SB-TONE-WSX

Smart Air - App / Voice Control

IT'S AS SIMPLE AS THAT.



- Automatic Pairing by Turning On the Switch
- Up to 700W
- Wallplate Included in the Package
- Standard Installation

Tunable White & Dimming Control System

DimTone offers a single-switch, end-to-end approach, eliminating redundant components and compatibility issues for superior performance. With its wireless support, DimTone requires only the same wire set as a standard dimmer switch, reducing installation time and costs. Just plug and play to start customizing your lighting in moments. Device pairing takes place automatically when the light is first switched on, with no technical knowledge needed.



Features & Benefits

- 120VAC Wall Switch with no Battery Required
- Simple Installation w/ no Extra Wiring or Controllers
- Smart Air - App / Voice Control
- Fits US Standard Gang Box
- Flicker-Free Soft Dimming - Down to 0.1%
- Dim-to-off
- Compliant to IEEE and Title 24 Flicker Requirements
- A Single Wall Switch Can Control Multiple LED Drivers
- No Compatibility Issues
- Classic Design to Match Existing Style Switches
- UL Listed

Wiring Overview

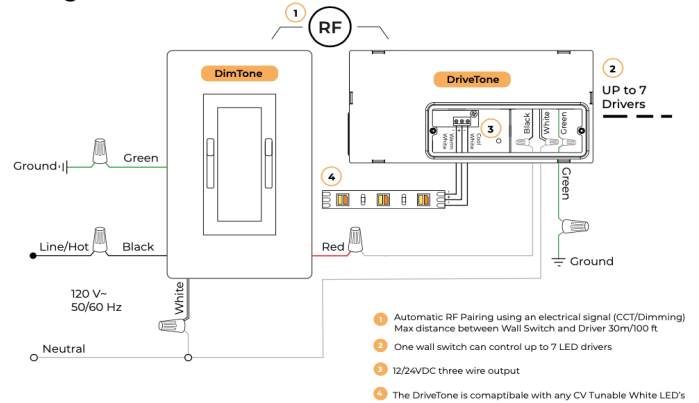

Electrical Specifications

Power & Ratings

Input	120VAC ~ 60Hz
Max Load	700W
Load Type	12/24VDC Tunable White LED's

Compliance

UL Listed	UL1472 / CSA C22.2 184.1
FCC	Class B Part 15

Environmental

Ambient Operating Temp	-30 °C - + 40°C / -86°F - + 104°F
IP Rating	23

Flicker Performance Graph

As defined in IEEE P1789, the results are presented with the low-risk in yellow and no observable effect in green.

Compliant to Title 24 Flicker Requirements.

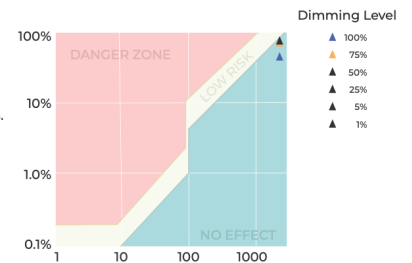

Performance Curves

Color Temperature

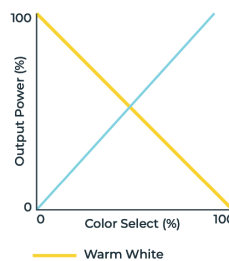

Dimming curve

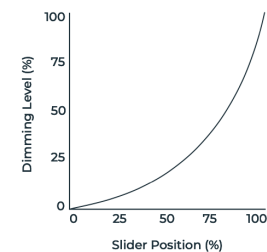

Dimming Performance

Control Protocol	RF (auto pairing)
Dimming Range	100% -0.1%
Dim to Off	Yes
Dimming Method	PWM (2400Hz)
Dimming Curve	Logarithmic (Default)

Mechanical Specifications

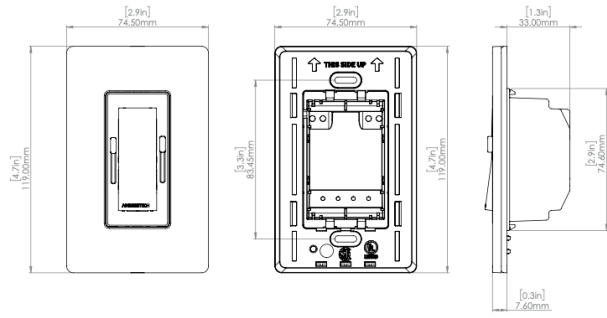

Note: Requires a U.S. wallbox 2" in (64 mm) deep minimum.

Material	PC/ABS - 5VA Rating
Finish	White Glossy (Default)

User Interface

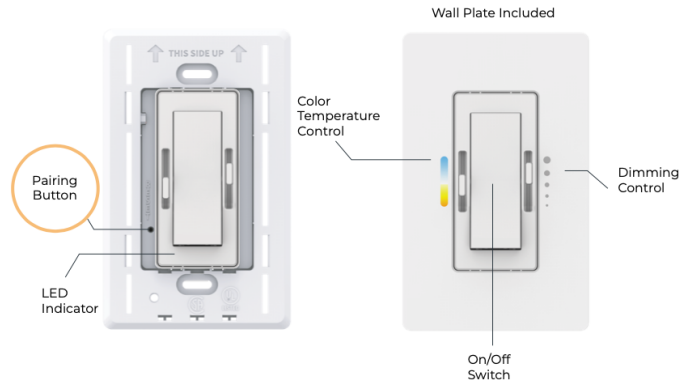

Smart Air - App / Voice Control



App Features



Smart Life control App set up Manual:

https://www.tlc-direct.co.uk/Technical/DataSheets/LEDlite_Smart/Smart_Life_Manual_en.pdf

DimTone Wall Switch Video:

<http://www.snowball-inc.com/en/media/videos/dimtone-tunable-white-amp-dim-wall-switch>

Smart Life control set up Video:

<http://www.snowball-inc.com/en/media/videos/tunable-white-amp-dim-smart-air-appvoice-control-set-up>

Installation Instructions



Item Identification

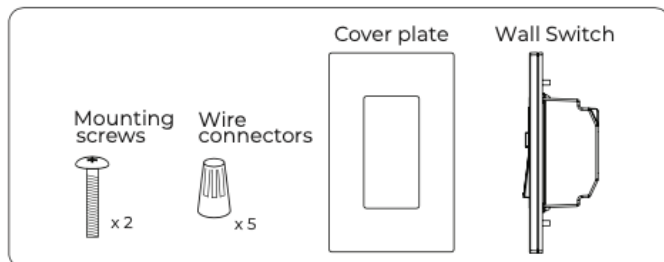

Tools Needed



Important Notes Please Read Before Installation!

- Neutral Wire required. If you don't have Neutral wire in the wallbox, please consult an electrician.
- The system is to be installed in accordance with the National Electrical Code or local code.
- The system is to be installed and serviced by a qualified, licensed electrician.
- Wall switch must be grounded in accordance with the NEC or local codes.

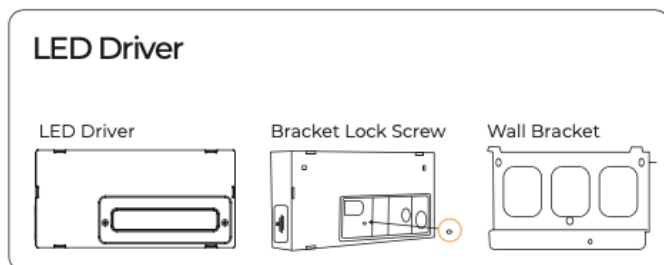

Overview of System Wiring

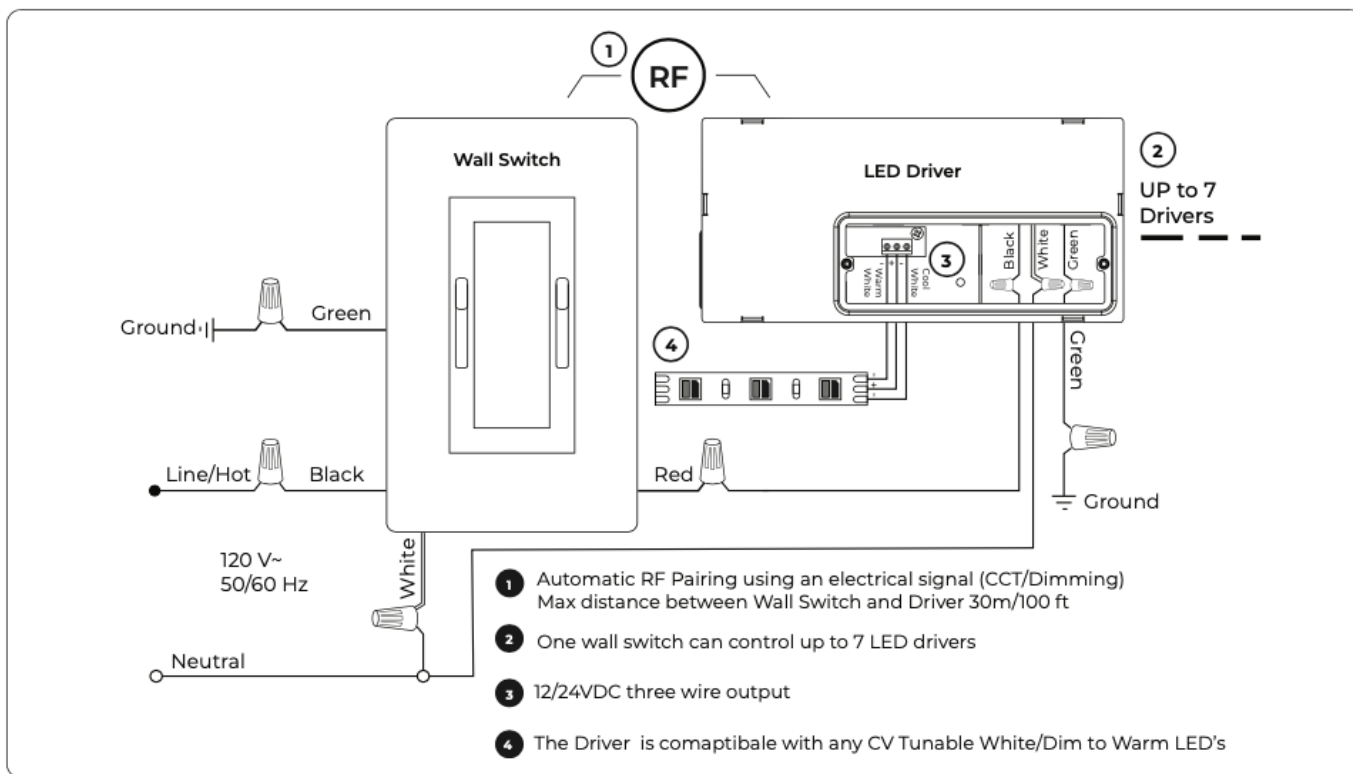

Installation Instructions

Wall Switch Installation

Wallbox

1. A standard single-gang wallbox sized 3 x 2 x 2 ½ cm will service Dimmer
2. Not compatible with multi or double Mud Rings.
3. When using a retrofit gang box (cut in box) you might need to recess the ears.

Maximum Load

Input voltage	Max Load
120VA	700W

Note : A maximum of 7 Drivers Led drivers can be controlled with each Dimmer.

Step 1 : Preparing Wall Box Wires

1. Make sure that the ends of the wires from the wallbox are straight (cut if needed).
2. Strip the wire insulation from each wire. in the wallbox as shown here :

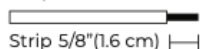

Step 2 : Wall Switch Wiring

Connect wires according to the wiring diagram below.

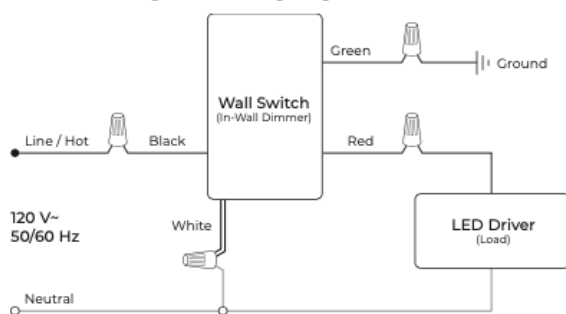

Wiring Description (Using wire connectors)

1. Connect the green (or bare copper) wire from the wallbox to the green Wall Switch wire.
2. Connect the line/hot wire from the wallbox to the black Wall Switch wire.
3. Connect the black LED Driver wire to the red Wall Switch wire.
4. Connect the white wire from the wallbox to the white LED Driver wire and the white Wall Switch wire.

Step 3 : Mounting the Wall Switch

Mount the Wall Switch into the wall box using the screws provided.

Step 4 : Restore power

1. Turn the power on at the circuit breaker.
2. Verify 120V with a Voltmeter

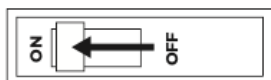

Pairing

Before starting the pairing process, if you are installing more than one Wall Switch unit, all others must be switched off when you pair each unit

1. Before starting, make sure both sliders are moved all the way up and Wall Switch is switched off.
2. Switch the power on at the circuit breaker, and the LED Indicator will light up in green.
3. Remove the sticker and turn on the Wall Switch paddle switch.
4. The green LED Indicator will blink while pairing.
5. After up to 15 seconds, your LED fixture should be paired with Wall Switch
6. To verify pairing is successful, move the sliders and ensure that the LEDs respond accordingly.
7. If you encounter a problem at any stage of the pairing process, follow through the instructions under "Reset".

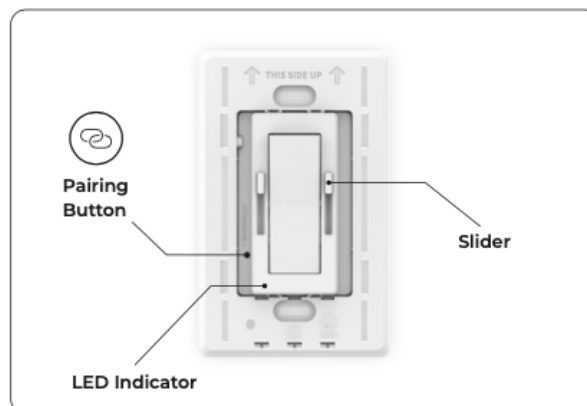

System Installation Complete!

Make sure the AT logo is on the bottom left corner.

Installation Instructions

Operation - Tunable White Wall Switch

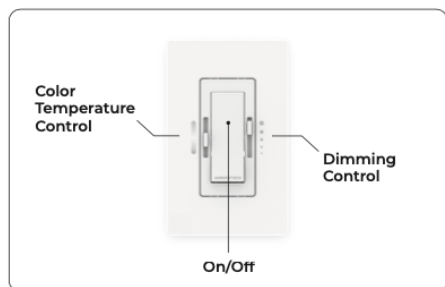

Reset

The reset process matches between the Wall Switch and the LED Driver/s connected to it. If you are replacing the Wall Switch or the LED Driver in an existing system, the reset process must be performed.

Important Note : if you are installing more than one Wall Switch unit, all others must be switched off when you pair each unit.

1. Before starting, make sure both sliders are moved all the way up and the Wall Switch is switched off.
2. Make sure that the power is turned on at the circuit breaker.
3. Push the Reset button using a toothpick or similar object – see the location of the Reset button in the below diagram.
4. The green LED Indicator will blink while pairing.
5. After a maximum of 15 seconds, your LED fixture should be turned on indicating that the reset process has been completed.
6. To verify pairing is successful, move the sliders and ensure that the LEDs respond accordingly.
7. If you encounter a problem at any stage of the pairing process, please check troubleshooting symptoms or contact our support team.

Caution

To Reduce the Risk of Overheating And Possible Damage To Other Equipment, Do Not Install To Control A Receptacle, A Motor-Operated Appliance, Or A Transformer-Supplied Appliance.

FCC/IC Information

This device complies with part 15 of the FCC Rules. Operation is subject to the following two conditions:

1. This device may not cause harmful interference
2. this device must accept any interference received, including interference that may cause undesired operation.

Operation - Dim to Warm Wall Switch

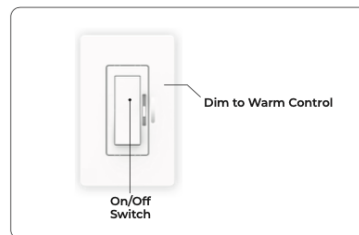

Trouble Shooting

Symptoms	Cause	Probable Action
Wall Switch LED Indicator blinking RED	Reset button is pressed while the wall switch is OFF	Turn ON the switch and press the reset button again
Wall Switch LED Indicator steady RED	Wall Switch is trying to perform pairing	Turn on the switch until pairing is complete
Lights do not respond to Wall Switch	Breaker is OFF or tripped	Turn power On at Circuit breaker
	Improper paring	Perform "Reset"
	Improper wiring	Make sure all wires are connected according to the wiring diagram
	Short circuit at the LED Driver output	Check LED driver output for short circuits
The wall switch is controlling the wrong lights (Only if multiple Wall Switch units are installed in the same location)	The Wall Switch was paired with the wrong LED Driver	Perform "Reset". Make sure all other Wall Switches are turned off while pairing
Wall Switch / LED Driver Replacement	Any reason	Perform "Reset". Make sure all other Wall Switches are turned OFF while pairing